

SMALL CLASSICAL TEMPLES L9250 & L9200

L9250 - COMPONENT LISTING

		WEIGHTS (each)	
X510C Dome sections	x3	27 kg	60 lbs
X511C Flange sections	x3	5 kg	11 lbs
X510E Ball final	x1	1 kg	2 lbs
L612 Upper cornice	x6	90 kg	198 lbs
L611 Lower cornice	x6	36 kg	79 lbs
L610 'U' beam	x6	86 kg	190 lbs
Tuscan column M700M/A/F/G	x6	195 kg	430 lbs
Total weight		2539 kg	5598 lbs

L9200 - COMPONENT LISTING

		WEIGHTS (each)	
X510C Dome sections	x3	27 kg	60 lbs
X511C Flange sections	x3	5 kg	11 lbs
X510E Ball final	x1	1 kg	2 lbs
L612 Upper cornice	x6	90 kg	198 lbs
L611 Lower cornice	x6	36 kg	79 lbs
L610 'U' beam	x6	86 kg	190 lbs
Tuscan column M700M/B/F/G	x6	206 kg	454 lbs
Total weight		2650 kg	5842 lbs

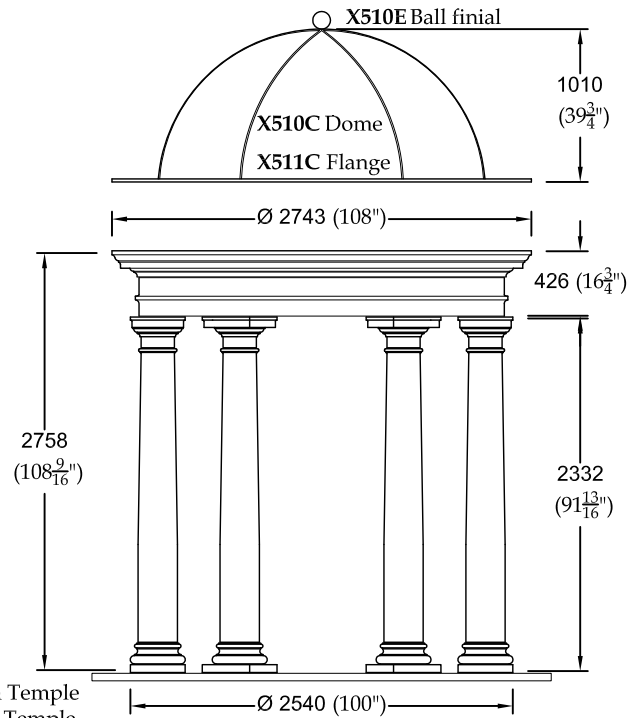
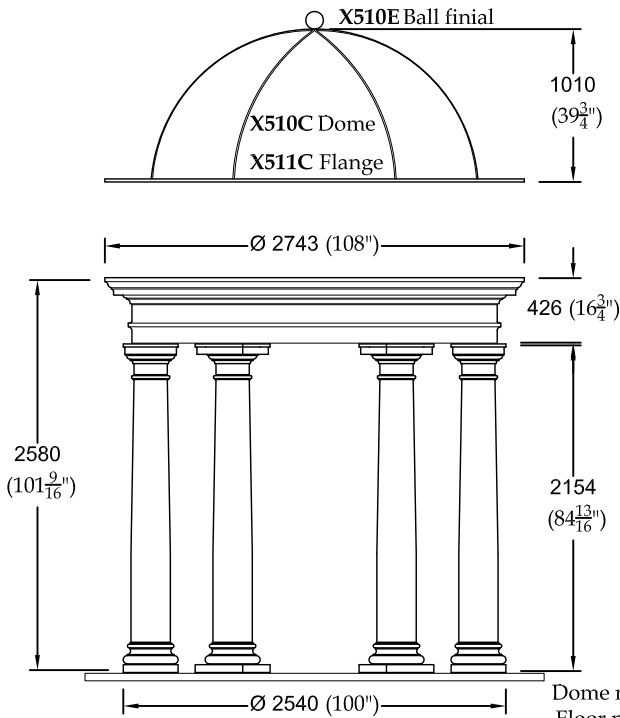

Dome not included with Temple
Floor not included with Temple
For floors see Tech-Sheet T25 and T35

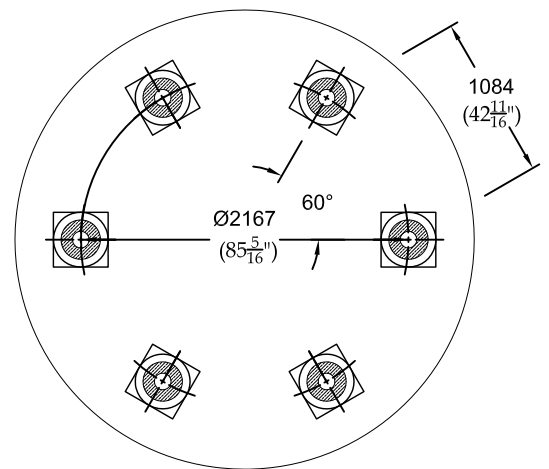
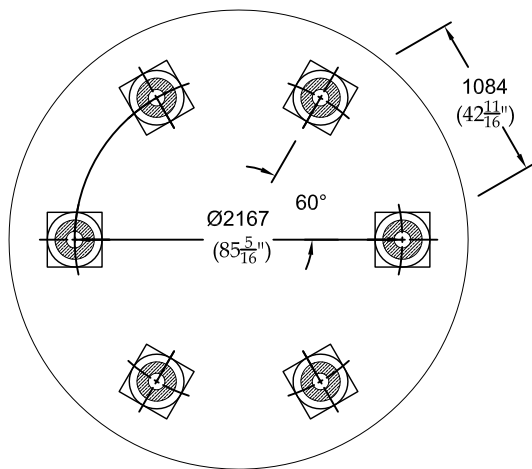

Read in conjunction with Tech Sheet T14, T25, T31, T35 and CAD1
All weights are approximate and should be used as a guideline only
All dimensions exclude joints - allow 6mm (1/4") for vertical and bedding joints

GRP dome supplied in sections for joining together on site by others
Glass fibre products for joint lamination supplied
Sealant not supplied